

Before you get started...

Equipment You Will Need:

- Tape measure
- Spirit level
- Pencil
- Workbench or sawhorse
- Combination square
- Spacers
- Tapping block
- Pull bar
- Rubber mallet
- Handsaw or electric saw
- Drill (for covering pipework)
- Moisture meter
- Beading or skirting boards
- Safety precautions i.e. knee pads, safety goggles, dust masks, ear defenders

1. Check The Packs

We would advise checking each pack to ensure you are happy with the product before proceeding with installation.

Due to the nature of wooden flooring each plank has its own unique natural variation, when laying your floor you can make the most of this contrast and design the perfect flooring for your home!

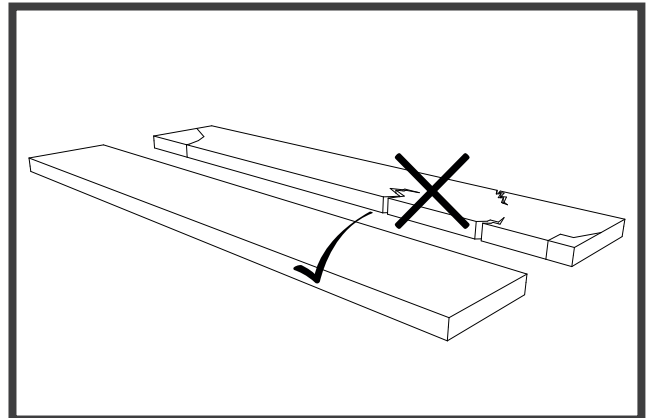

2. Allow Packs To Acclimatise

You should allow your solid wood to acclimatise outside of the pack for 5-7 Days.

Try to ensure the room stays at the same temperature you'd usually have it at so between 18 and 27°C and don't allow the floors to be exposed to the elements. If you're using underfloor heating, you'll need to gradually increase the temperature to get the wood used to the heat. We would strongly advise that you refer to the advice given by your heating supplier on how to do this.

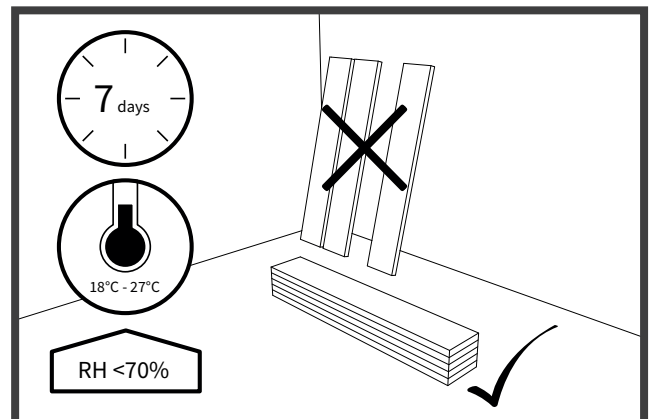

3. Prepare The Subfloor

In preparation of your new flooring you will need to remove your existing floor and ensure that the subfloor is clean and free of any debris.

If you have a concrete subfloor, make sure it's completely dry before installation. A damp-proof membrane should be installed on top of the subfloor to reduce the risk of moisture reaching the solid wood boards.

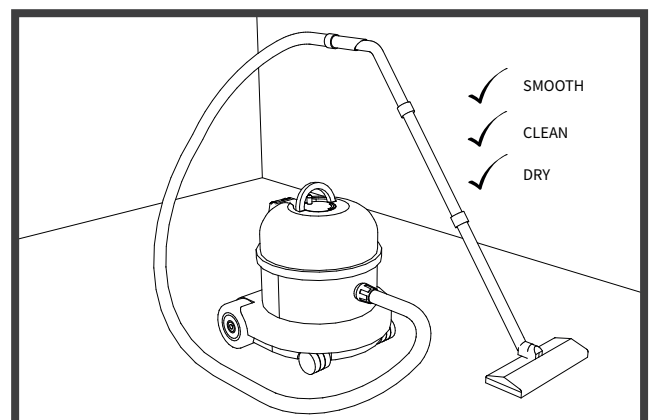

Before you get started...

4. Plan The Look

Before beginning to lay your new floor.

Take the planks from each pack and look at the natural grains and deviations in shade. Select your favourites and use these planks as a focal point, whilst ensuring to mix and match shades and patterns around these so that you can get the desired look in your rooms. Should there be any planks you don't love as much as others, these would be the perfect choice for cuts, or in areas that will be covered by furniture or rugs.

Consider the direction you would like your planks to lie. As a general rule of thumb, lay the boards against the longest wall for the best look. If the room is square, you may want to consider the room's light flow, or follow on from the entrance.

Most fixed length board packs come with a starter plank in the pack. This is the shorter piece of wood that you should use to begin laying the pattern so that the flooring has a staggered effect. For random length plank flooring, mix and match the length so you get a dappled natural look.

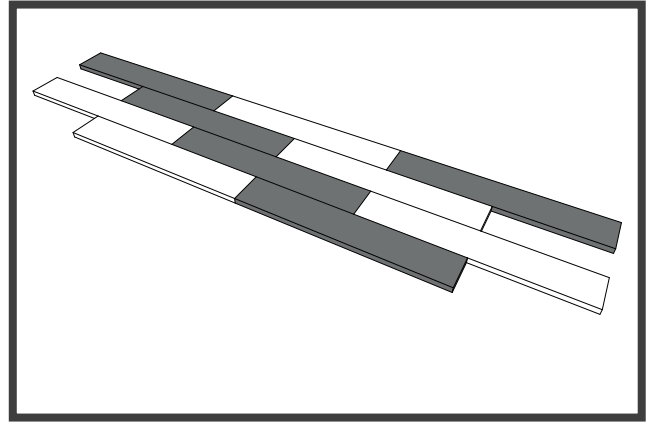

5. Installation Tips

It's best to fit your floor as the last thing you do in a renovation project.

To reduce the risk of damaging your new flooring we would strongly advise installing your floor as the last step in your renovation, work your way from the top of the room to the bottom. Always fit the floor after units have been installed, this will make sure the floor does not buckle under the weight of the units.

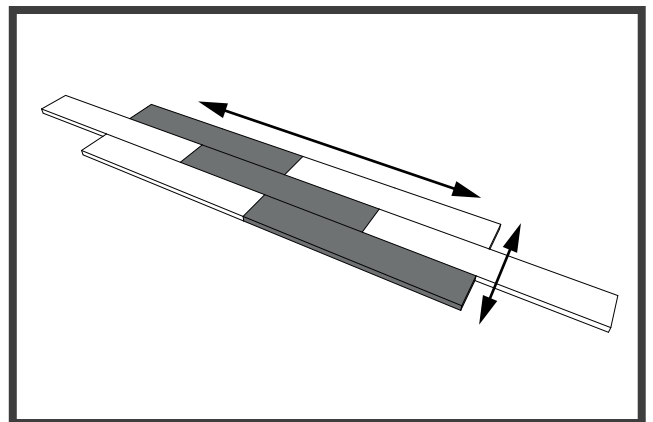

Installation Guide - Gluing Method

Step 1.

Before you begin and lay the boards, you will need to measure the width of the final row. You can do this by dividing the total width of the room by the width of an individual board. This will allow you to cut down the first row of boards to ensure the final row is at least 60mm wide.

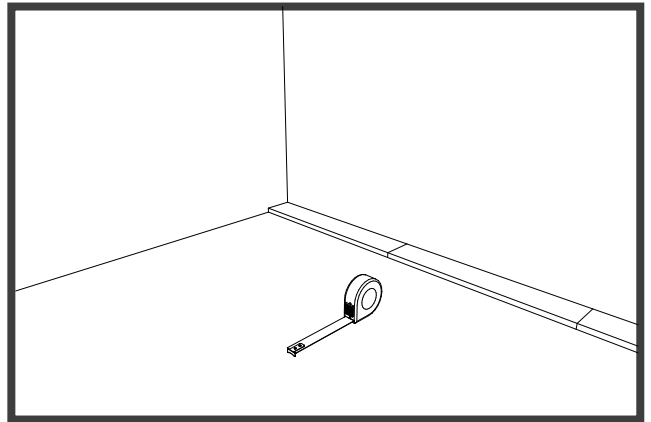

Step 2.

Measure 1 metre out from the longest wall and apply the adhesive before laying your first row.

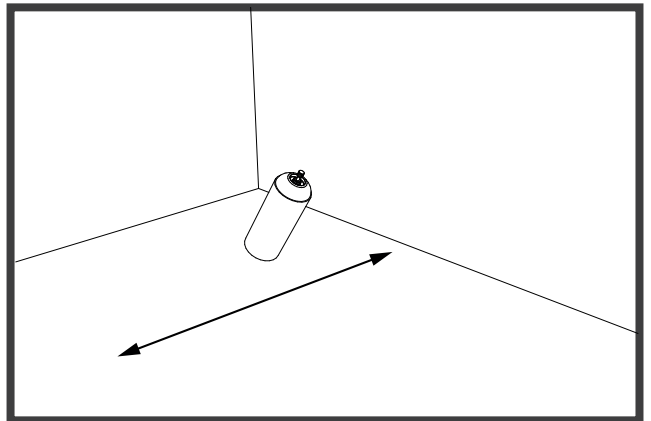

Step 3.

The first plank should be laid in the corner of the longest wall with the tongue edge facing the wall. Make sure this row is perfectly straight as this will set the direction for the rest of the floor.

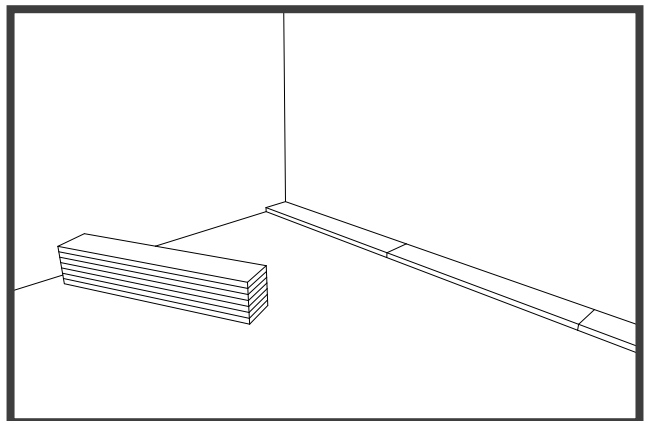

Step 4.

Place spacers between the first row and the walls to create an expansion gap that will allow for any minor movement and expansion that may occur after installation

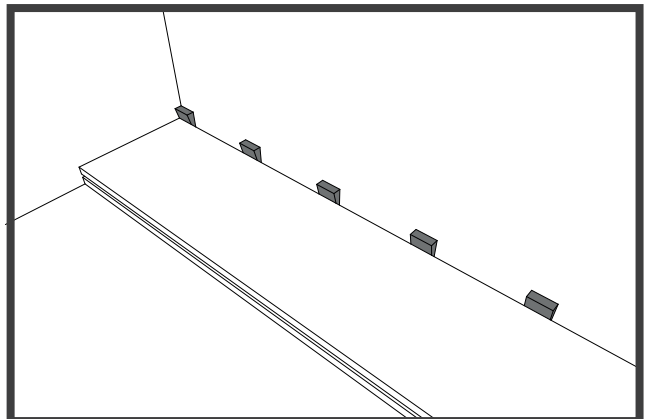

Installation Guide - Gluing Method

Step 5.

Continue laying the planks and ensure you place approximately 1 meter of adhesive ahead of the previous row and stagger the joints from row to row to create a natural wood appearance.

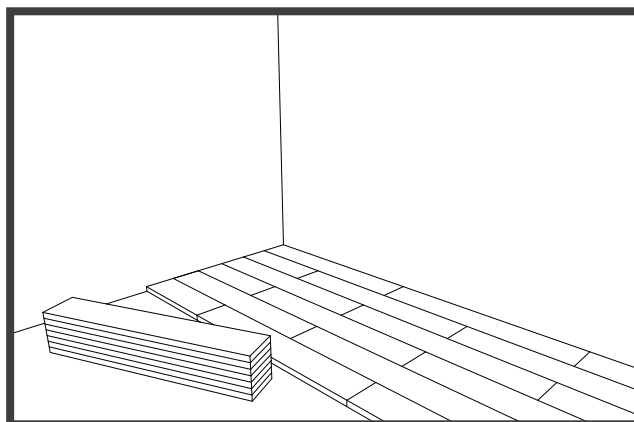

Step 6.

Ensure that you place spacers around the sidewalls and between rooms to allow for any expansion.

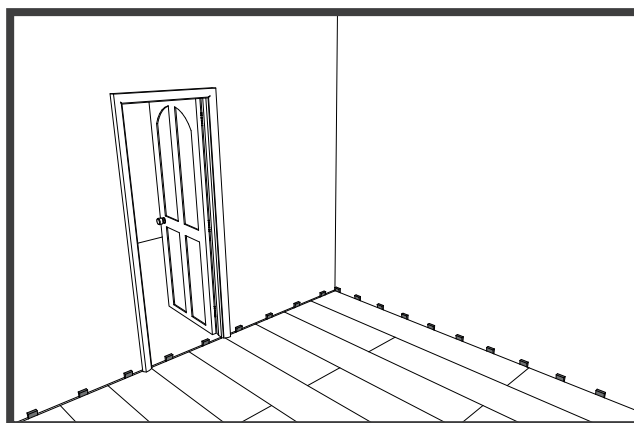

Step 7.

The last row of flooring may be slightly tricky to install, but a pull bar and rubber mallet can help to create a tight and secure fit.

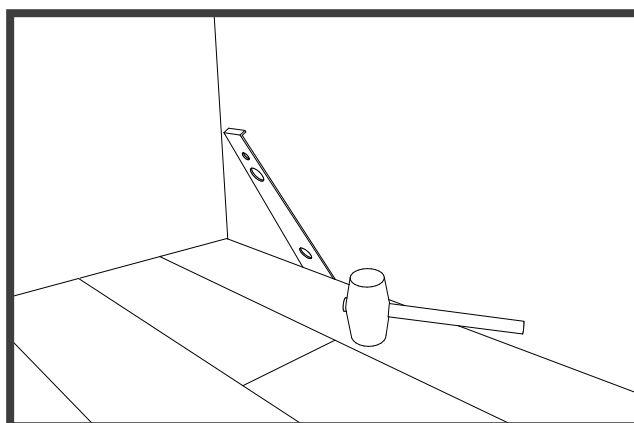

Step 8.

Leave the floor for 24 hours before moving furniture back into the room or walking on it.

Finishing Touches

- If you are fitting your new wood flooring around pipes, first mark the position of the pipe in the board with a pencil. Then carefully drill a hole in this position and make two angled cuts with a saw. These cuts should form a wedge from the edge of the board to the hole which can then be removed. Fit the board around the pipe and then reattach the wedge with a small amount of glue behind the pipe so the plank looks intact.
- You can use matching scotia beading and doorbars to cover any expansion gaps and blend your new floor in with your existing walls and joining rooms, creating a professional and seamless finish.
- If possible we would always advise keeping any spare planks or cuttings in case any repairs are needed to be made in the future.
- If the expansion gap has been left too large and the skirting board or scotia doesn't cover it, you can use spare floorboards to cut strips using a hand saw and glue these strips into place.

DISCOVER THOSE PERFECT FINISHING TOUCHES...



Pipe Covers



Profiles



Skirting Boards



Scotia Beading